

Stationary Compactor

Description

A powerful commercial compactor that remains anchored (stationary) at all times after installation. Waste is loaded into the hopper and compacted into a receiving container. These units are recommended for general dry office trash, paper and cardboard.



Specs

- ▼ Minimum WASTEC rating 1.3 cy capacity
- ▼ Minimum clear top opening: 40" x 57"
- ▼ Motor size: 10 HP
- ▼ Minimum 48" ground feed height
- ▼ Rebuilt cylinder(s)
- ▼ Add new hydraulic hoses, fittings, oil and filters
- ▼ Clearly marked controls
- ▼ Safety switches on all service doors
- ▼ Safety decals
- ▼ Cleaned and painted
- ▼ ANSI Z245.2 compliance
- ▼ Equipment comes with a warranty
- ▼ Rentals come with full maintenance

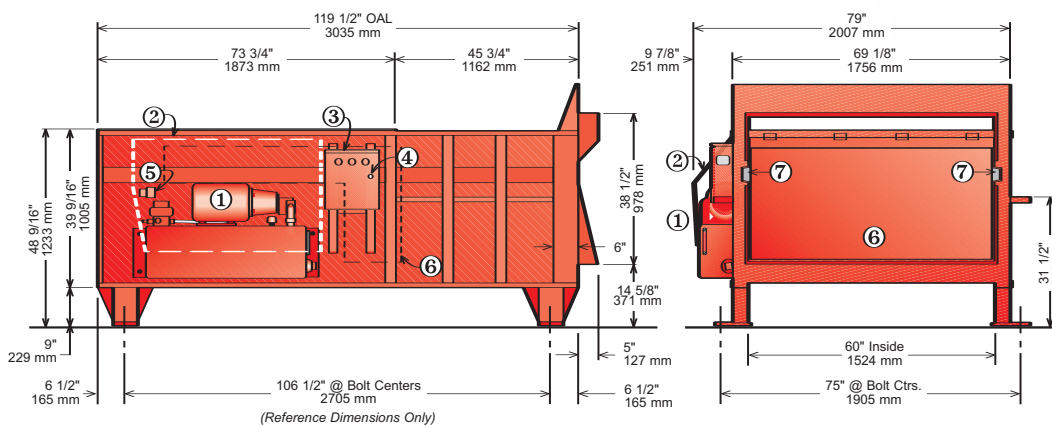
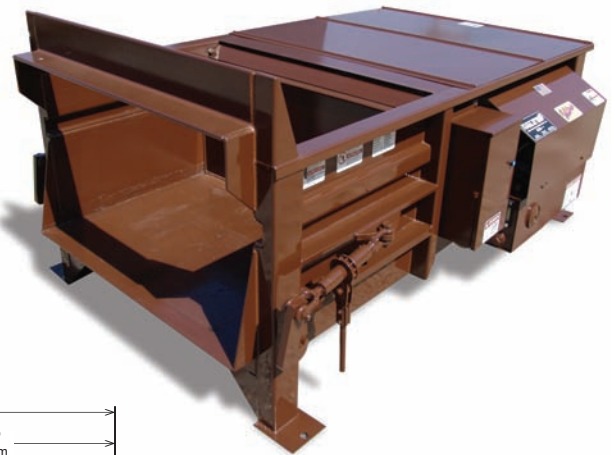

Concrete Pad Requirements

6" (152 mm) Thick Reinforced 3000 PSI Concrete (4) 3/4" (20 mm) Anchor Bolts (Min.)

Distributor:

Greenleaf Compaction, Inc.

4001 N. 3rd St., Suite 480

Phoenix, AZ. 85012

1-800-932-7718

www.GreenleafCompaction.com