

# Vertical Balers

## Description

Vertical balers are designed for industrial and commercial recycling needs. They are capable of baling paper, cardboard, foam rubber, plastics, and aluminum cans. They come in several sizes and can produce bales weighing 250-1800 lbs. (OCC).

## Specs

- ▼ Clearly marked controls
- ▼ Safety door with security switches
- ▼ Safety decals
- ▼ Cleaned and painted
- ▼ ANSI Z245.5 compliance
- ▼ Equipment comes with a warranty
- ▼ Rentals come with full maintenance



V-6030 HD

V-7230 HD

### Dimensional Data:

<b>A</b> Overall Width (w/auto-eject)	89 1/4"	101 1/4"
<b>B</b> Overall Depth	41 1/2"	44 1/2"
<b>C</b> Overall Depth (w/optional wire guides)	54 1/2"	57 1/2"
<b>D</b> Overall Height	140"	142"
<b>E</b> Feed Height	48 1/4"	50 1/4"
<b>F</b> Feed Opening Width	60"	72"
<b>G</b> Feed Opening Height	25"	25"
<b>H</b> Bale Door Clearance	58"	70"

### Bale Size Data:

Bale Size	60"W x 30"D x 48"H	72"W x 30"D x 48"H
Bale Volume	50 cu.ft.	60 cu.ft.
Bale Weight (OCC)	Up to 1,100 Lbs	Up to 1,400 Lbs
No. Bale Ties (14 ga. x 14ft. long):	6	6
<b>Total Baler Weight:</b>	4,300 Lbs	5,400 Lbs

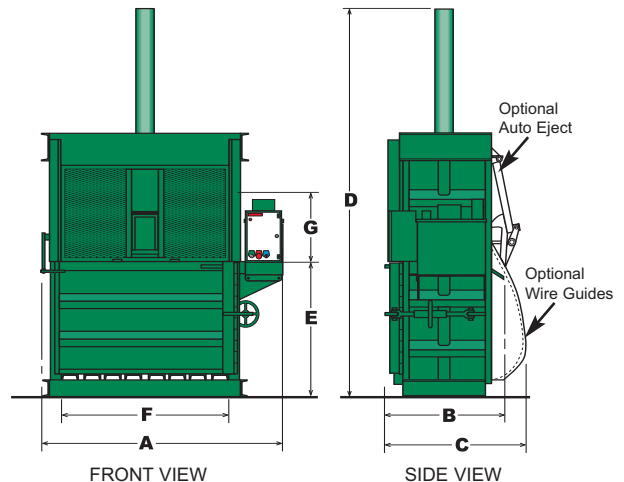

Distributor:

### Greenleaf Compaction, Inc.

4001 N. 3rd St., Suite 480  
Phoenix, AZ. 85012  
**1-800-932-7718**

[www.GreenleafCompaction.com](http://www.GreenleafCompaction.com)